

NB: Where applicable and dependent on the compressor model, align the supplied drive belt by installing in the correct clutch groove - Fig.9 Seltec PV8 has the same gauge line (46.55) as the Sanden PV6 & PV7, belt is fitted to front groove. Sanden PV8 has a unique gauge line (50.11) in most cases, belt is fitted to second groove. If in any doubt, please check with your compressor supplier

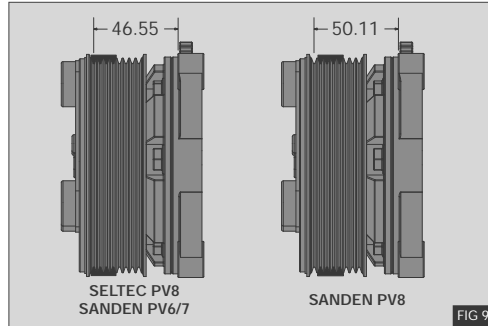

3. Tension the drive belt to correct tension (see table) using the supplied eccentric tool (9), tighten bolt (5), to lock eccentric pulley - Fig 8
4. Torque bolt (9) to 25 Nm / 18 lb ft.

BELT TENSION TABLE		
Belt	Belt Age	Belt Tension Using the Belt Tension Gauge
4PK	New Belt	48 - 56 kg
4PK	Used Belt	36 - 40 kg

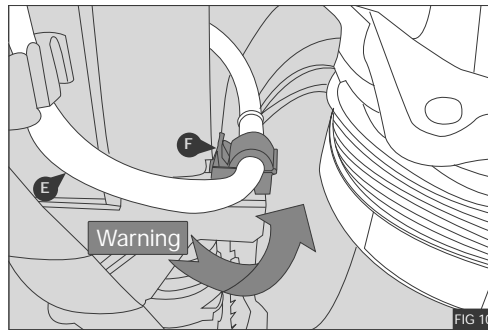

PIPE SUPPORT MODIFICATION

1. Remove the original Iveco pipe (E) from the securing clip (F) Fig 11
2. Secure the Iveco pipe (E) with the supplied p-clip (12) to the original bracket (G) with bolt (13) and nut (14) - Fig 11
3. Fit the supplied Split tubing (15) to the Iveco pipe as shown in Fig 11

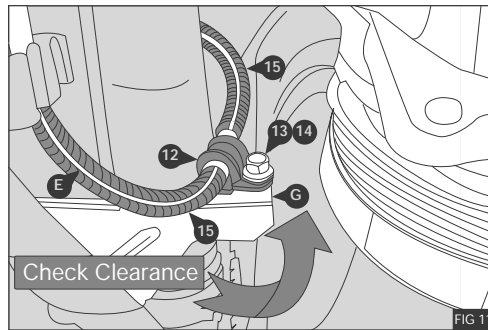

Warning: Check for adequate clearance between the compressor and pipe assembly.

POST INSTALLATION

1. Before starting the engine check all the installed parts and ensure that the belt is installed correctly. Run the unit for at least ten minutes, then check the whole mounting assembly and previously removed parts and re-tension the drive belt. Attach the supplied warning label on to a suitable location.

Contents

ENGLISH 2

- Vehicle Details..... 2
- Adapter Kit Details..... 2
- Compatible Compressors 3
- Compressor Kit Configurations 3
- Foreword 4
- Standard Fastener Torque Values..... 4
- Parts View and List 5
- Pre Installation 6
- Crankshaft Pulley Installation..... 6
- Mount Bracket Installation 7
- Drive Belt..... 7
- Pipe support modification 8
- Post Installation 8

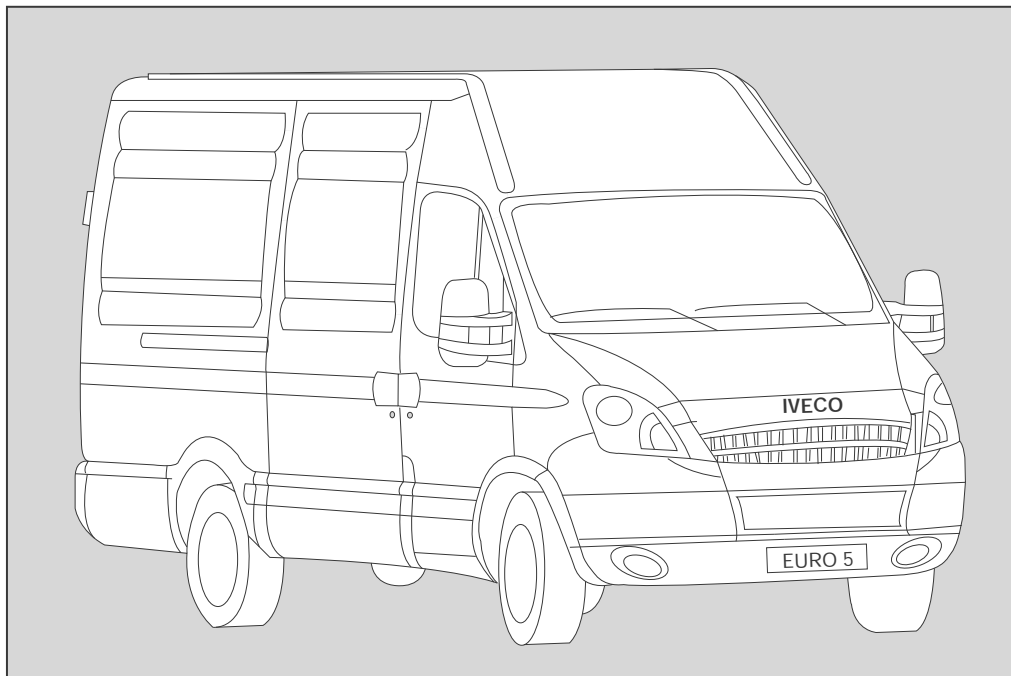

VEHICLE DETAILS

Manufacturer	Iveco
Make	Daily
Model	29L 11/13/15, 35S 11/13/15 35C 11/13, 40C 11/13
Engine CC	2286
Engine Details	Euro 5 F1A - 106/126/146
Year	10.2011>
Chassis Nos.	N/A
LHD	YES
RHD	YES
PAS	YES
A/C	NO
Voltage	12v

KIT DETAILS

Kit Part No.	0500.6372
Description	Standard Kit
Compressor RPM	3900 @ Max Engine
	Power Output
Fitting Time	45 Minutes
Suction Fitting	90°
Discharge Fitting	90°
Belt Type	4PK 925
Belt Part No.	0820.5591

MOUNT BRACKET INSTALLATION

1. Fit the supplied compressor mount bracket ① to the engine using the three bolts ③ M8 x 45 and one bolt ④ M8 x 50 - Fig 5
2. Torque bolts ③ & ④ to 25Nm / 18Lb ft

NB: Please refrain from using "Loctite" unless otherwise notified

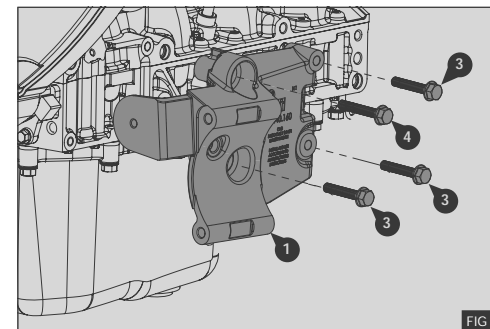

FIG 5

3. Fit the Compressor to Mount Bracket ① using the four bolts ⑥ M10 x 30 - Fig 6
4. Torque bolts ⑥ to 50Nm / 37lb.ft.

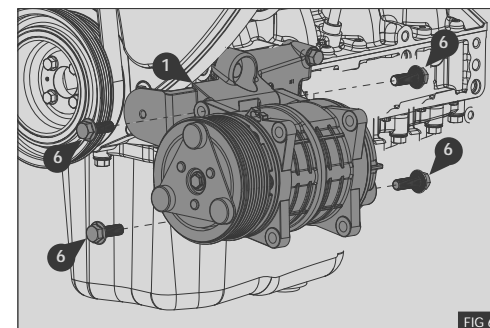

FIG 6

5. Fit the supplied Eccentric pulley ⑩ to the mount bracket ① using bolt ⑤ M8 x 35, do not tighten at this stage - Fig 7

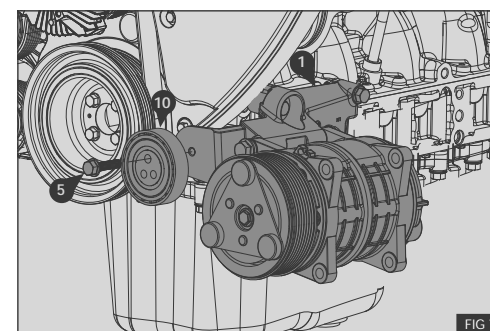

FIG 7

DRIVE BELT

1. Re-fit the original Alternator, Power steering & Fan Belt into position shown in Fig 1
 2. Fit the Compressor Drive Belt ⑨ - Fig 8
- A. Compressor
B. Eccentric Pulley
C. Crankshaft Damper

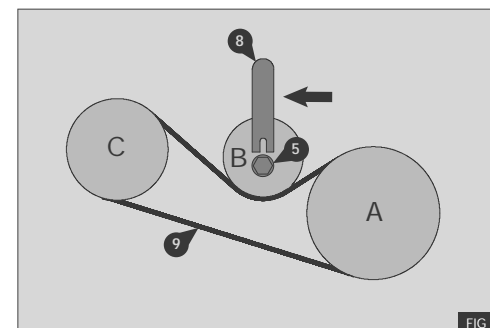

FIG 8

PRE-INSTALLATION

N.B Prior to commencing work, please examine the instructions with care. The alphabetical symbols on the diagram relate to written instructions, numerical symbols relate to the parts listing.

Dismantle the following:

1. Remove the engine under panel 2 x M6 Bolts and 4 x M8 self tapping screws.
2. Using a suitable tool rotate the automatic belt tensioner pulley (A) clockwise - Fig.1
3. Remove the original manufacturers poly groove drive belt (B) noting the original routing, if different from the diagram shown in Fig.1 report your findings to your Kit/System supplier before proceeding.
4. Remove and retain the four crankshaft pulley bolts (C) - Fig 2
5. Remove and retain the crankshaft damper (D) from the engine.

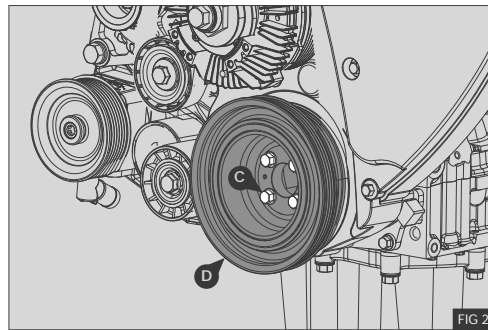
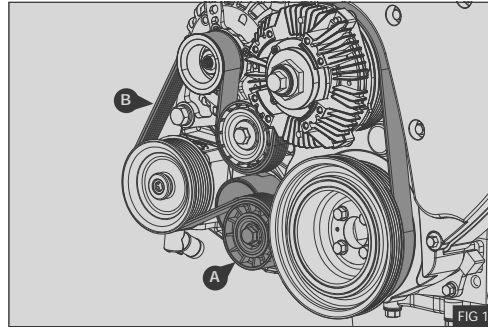

CRANKSHAFT PULLEY INSTALLATION

1. Align the supplied crankshaft pulley (11) with the pre drilled holes in the Iveco crankshaft damper (D) .
2. Fit the supplied roll pins (7) through the supplied pulley (11) into the crankshaft damper (D) - Fig 3
3. Refit crankshaft damper assembly (B) and supplied compressor drive pulley (11) using original bolts (C) - Fig 4
4. Torque bolts to 30Nm / 22lb.ft.

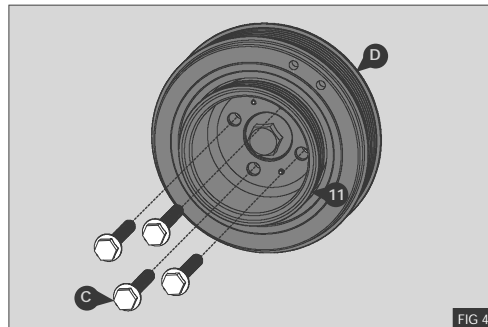
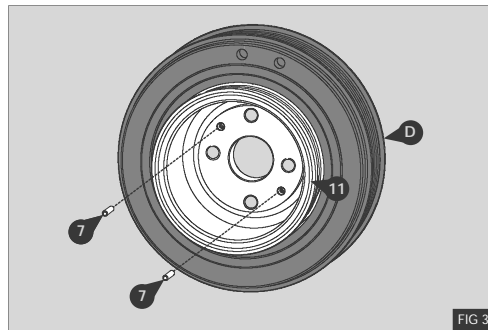

Warning: Follow the procedure carefully to insure correct positioning of the compressor drive pulley.

COMPATIBLE COMPRESSORS

SELTEC	TM-13 HS	TM15-HS	TM16-HS
Comp No	0381.0352	0381.5002	0831.0372
Alt No.	488-44122	488-45122	488-46122
Mounting	Ear	Ear	Ear
Rotor	8PV	8PV	8PV
Armature	3E	3E	SL
Diameter	123	123	123
Voltage	12	12	12
Orientation	H	H	H
Fitting	3/4 x 7/8	3/4 x 7/8	3/4 x 7/8
Manifold	Bolt	Bolt	Bolt

QUE	QP13-HD	QP15-HD	QP16-HD
Comp No	0391.0352	0391.5002	0391.0372
Que No.	QP13-1274	QP15-1266	QP16-1197
Mounting	Ear	Ear	Ear
Rotor	8PV	8PV	8PV
Armature	3E	3E	3E
Diameter	123	123	123
Voltage	12	12	12
Orientation	H	H	H
Fitting	3/4 x 7/8	3/4 x 7/8	3/4 x 7/8
Manifold	Bolt	Bolt	Bolt

SANDEN	SD5H09	SD5H14	SD5H15
Comp No	-	0300.0451	0300.1961
Sanden No.	-	6628	8027
Mounting	-	Ear	Ear
Rotor	-	7PV	8PV
Armature	-	SL	SL
Diameter	-	124	125
Voltage	-	12	12
Orientation	-	H	H
Fitting	-	3/4 x 7/8	3/4 x 7/8

Notes

COMPRESSOR KIT CONFIGURATIONS								
PART NUMBER	COMPRESSOR KIT PART NOS						DESCRIPTION	QTY.
	0513.6372	0515.6372	0516.6372	0593.6372	0595.6372	0596.6372		
0381.0352	●						TM13 Ear Mount 8PV 3E 123 12V H 3/4 x 7/8 Bolt	1
0381.5002		●					TM15 Ear Mount 8PV 3E 123 12V H 3/4 x 7/8 Bolt	1
0381.0372			●				TM16 Ear Mount 8PV 3E 123 12V H 3/4 x 7/8 Bolt	1
0391.0352				●			QP13 Ear Mount 8PV 3E 123 12V H 3/4 x 7/8 Bolt	1
0391.5002					●		QP15 Ear Mount 8PV 3E 123 12V H 3/4 x 7/8 Bolt	1
0391.0372						●	QP16 Ear Mount 8PV 3E 123 12V H 3/4 x 7/8 Bolt	1

● = Additional parts to standard kits.

FOREWORD

1. The purpose of this manual is to facilitate the installation of a direct drive compressor. The information given is merely instructive, should any complications arise contact the Technical department. The manufacturer's warranty does not cover any problems caused by defective installation or alterations made unless authorised. The manufacturer shall not be responsible for any injury, damage or loss caused directly or indirectly as a result of using this manual or the information contained within it.

1 SAFETY MEASURES:

Before fitting the Compressor adapter drive kit, ensure the following for damage:

- a Inner and outer trim and body work
- b Engine idle pace
- c Check all the vehicle functions

Check list:

- a Ensure that the right kit has been selected
- b Before installing, check that all the correct pieces are present; also ensure that there are no missing or broken pieces
- c When fitting, make sure the vehicle is properly protected against damage.

Installation apparatus

- a Calibrated torque wrench
- b Hand service tools
- c Protective covers and shields

2 PRECAUTIONS

- a Detach the battery negative lead.
- b Torque all bolts where stated using a calibrated torque wrench.
- c Take extreme care with moving parts.
- d Remove the vehicles ignition key and keep it with you.
- e Wear eye safeguards and to make sure that liquid refrigerant never touches your skin

Caution: Measures must be followed accurately to steer clear of the possibility of damage to individuals

Warning: This calls awareness to actions which must be pursued to avoid damage to the components.

NB: This calls awareness to make the job easier or gives useful information.

STANDARD FASTENER TORQUE VALUES

1. In the absence of specific torque values detailed in this fitting instruction manual, the following chart can be used as a guide to the maximum safe torque for specific size and grade of fastener.

STRENGTH	4.8		8.8		10.9		12.9	
	Max Torque		Max Torque		Max Torque		Max Torque	
Dia / Pitch	lb.ft	Nm	lb.ft	Nm	lb.ft	Nm	lb.ft	Nm
M5 x 0.80	2	3	4.5	6	6.5	9	7.5	10
M6 x 1.00	4	5.5	7.5	10	11	15	13	18
M8 x 1.25	10	13	18	25	26	35	33	45
M10 x 1.25	20	27	39	53	57	78	66	90
M10 x 1.50	18	25	37	50	55	73	63	86
M12 x 1.75	33	45	63	85	97	130	111	150
M14 x 2.00	55	75	103	140	151	205	177	240
M16 x 2.00	85	115	159	215	232	315	273	370

PARTS VIEW

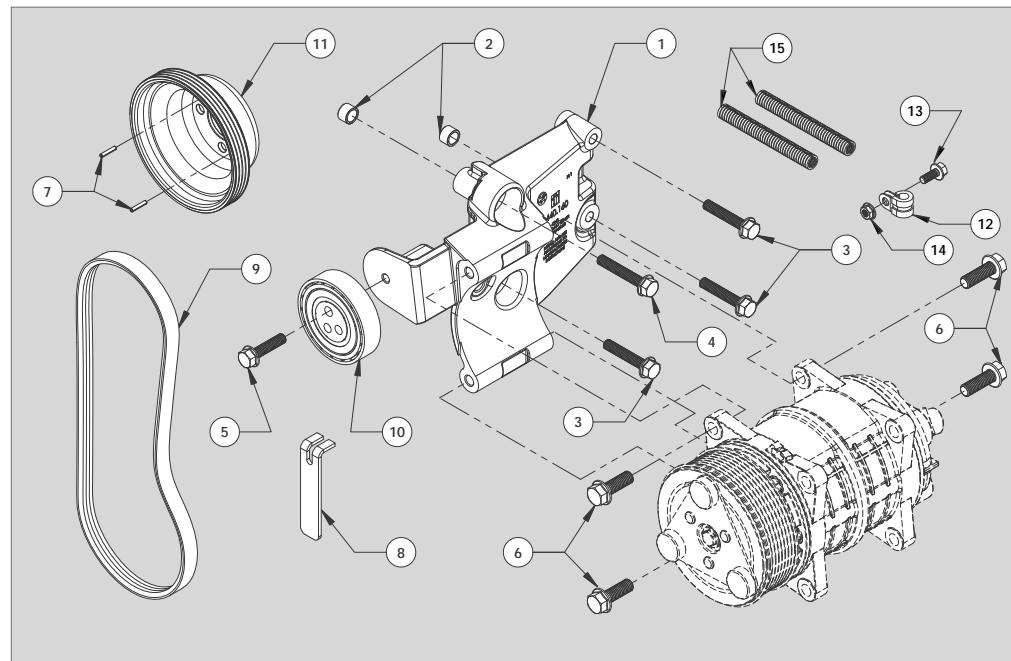

ITEM	PART NO.	DESCRIPTION	QTY.	COMMENTS
1	0440.1603	Compressor Mount Bracket	1	-
2	2800.0291	Dowel Bush	2	-
3	2704.0161	Hex flange bolt durlok - M8 x 45 : 1.25 - 12.9	3	-
4	2704.0101	Hex flange bolt - M8 x 50 : 1.25 - 10.9	1	-
5	2704.0481	Hex flange bolt durlok - M8 x 35 : 1.25 - 12.9	1	-
6	2705.0491	Hex flange bolt durlok - M10 x 30 : 1.50 - 12.9	4	-
7	2762.0031	Spring Pin ISO 8752 - 3 x 16	2	-
8	3020.3863	Eccentric Pulley Adjusting tool	1	-
9	0820.5591	Belt - Poly Groove 4PK 925	1	-
10	1700.0371	Eccentric Idle Pulley	1	-
11	1701.5073	Crankshaft Drive Pulley	1	-
12	2771.0531	P-Clip 11mm	1	-
13	2702.0131	Hex flange bolt durlok - M6 x 16 : 1.00 - 12.9	1	-
14	2732.0041	Hex flange nut durlok - M6 : 1.00	1	-
15	1430.0041	Conduit split tube - 12mm	2	-